



Method Statement

Ref. #: DCP00/08-0106-A-2024



Aquathane E400

[One component, water-based polyurethane liquid membrane for waterproofing and protection]



Table of Content

SECTION A: GENERAL COMMENTS	3
General Notes	3
High-Temperature Working	3
Low-Temperature Working	3
System Products	3
Tools and Equipment	4
SECTION B: APPLICATION	5
Substrate Preparation	5
Priming	6
Dilatation Joints and Inner Angles	6
Application	7
Application Details	8
Cleaning and Storage	9
SECTION C: CAUTIONS	9
Health & Safety	9
SECTION D: APPROVAL AND VARIATIONS	9



Section A : General Comments

General Notes:

The information below is a detailed overview of the application of DCP's **Aquathane E400** waterproofing and protection system and should be read in conjunction with the relevant technical data sheet prior to application. All DCP Products should be applied by experienced specialist contractors.

All the points below assume the correct preparation of the relevant surface.

High-Temperature Working:

Application temperature ranges from 5°C to 40°C. The substrate's temperature must be at least 3°C above measured dew point temperatures if any.

It is suggested that, for temperatures above 40°C, the following guidelines are adopted as good working practice:

- i. Unmixed materials and equipment should be stored in a cool shaded area and away from direct sunlight.
- ii. Avoid application during peak temperature of the day.
- iii. Plan for enough materials, tools, and labor to ensure continuous applicant process.
- iv. Ensure proper and adequate ventilation.

Low-Temperature Working:

It is suggested that, for temperatures below 10°C, the following guidelines are adopted as good working practice:

- i. Unmixed materials should be stored in a warm.
- ii. Avoid applying the waterproofing membrane if the temperature is around 5°C and falling.
- iii. Do not apply under rain or snow, and avoid dew points conditions during application.

System products:

Sealant: **Flexseal PU425/PU440**

Main Membrane: **Aquathane E400**

Reinforcing Geotextile: **DonFlash H**

Tools and Equipment:

It is suggested that the following list of equipment are adopted as a minimum requirement

- Personal protection* : *Protective overalls*
- : *Goggles or a face mask*
- : *Good quality gloves*
- : *Safety shoes*
- : *Safety helmet*

- Preparation equipment* : *Stiff wire brush (Fig.1)*
- : *Soft brush (Fig.2)*
- : *Air compressor with hose (Fig.3)*

- Application equipment* : *Brush (Fig.4)*
- : *Roller (Fig.5)*
- : *Airless spray (Fig.6)*



Fig.1: Stiff wire brush



Fig.2: Soft brush



Fig.3: Air compressor with hose



Fig.4: Brush



Fig.5: Roller



Fig.6: Airless spray machine

Section B : Application

1.0 Substrate Preparation

- 1.1 The substrate should be clean, sound, smooth, and free from contamination such as mortar and paint splashes, curing compounds, oil, and grease.
- 1.2 Excess laitance deposits are best removed by grit blasting or wire brushing followed by blowing using an air compressor and hose to remove all loose debris. All preparation equipment should be of a type approved by DCP.
- 1.3 Ensure the substrate surface is dry with no standing water, smooth, and any surface imperfections are repaired with a suitable cementitious repair mortar. Consult the DCP's Technical Department for specific recommendations.



Repair of surface imperfections using cementitious repair mortar

- 1.4 Cracks in the substrate over 2.5 mm in width should be treated using one component flexible sealant **Flexseal PU425 or PU440**.



Repair of cracks using Flexseal PU245 or PU440

- 1.5 Where these methods are considered impracticable, alternative methods may be considered but a clean, sound, and dry substrate must still result. In particular, it is essential that the substrate does not suffer from conditions of rising damp. Any alternative preparations must be approved by DCP prior to the commencement of work, as the final performance of the system relies upon the performance of sound and level substrates.

2.0 Priming

- 2.1 **Aquathane E400** does not require priming, it can be directly applied over well-prepared substrates.
- 2.2 For extremely porous substrates, it is recommended to dilute **Aquathane E400** with water at a ratio of 1:1 by volume, and use this mix as a primer.
- 2.3 Apply the primer at a rate of 5 m²/litre onto the clean substrate using a roller, brush, or airless spray.



Application of Aquathane E400 diluted with water as a primer

- 2.4 Leave the primer to dry before applying subsequent coats. Drying time will depend on the ambient and substrate temperature and substrate porosity.
- 2.5 For fairface concrete surfaces, roughening the surface before application is needed. Alternatively, If roughening is not possible, **Recoat Primer** should be used.

3.0 Dilatation Joints and Inner Angles

- 3.1 Dilatation joints and inner angles should be treated with **Flexseal PU425 or PU440**. A coving detail must be formed at all corners and normal PVC pipes minimum 1 cm x 1 cm fillet.



Application of Flexseal PU425/440 in joints

4.0 Application

- 4.1 Stir the material in the bucket well before use.
- 4.2 **Aquathane E400** can be applied using a brush, roller, or airless spray machine
- 4.3 Apply the first coat at a rate of 0.55 – 0.65 kg/m². Do not leave more than 24 hours between two coats of **Aquathane E400**.
- 4.4 Reinforcement geotextile **DonFlash H** reinforcing fleece is recommended to be placed at all corners and angle changes (e.g. floor to wall connection), with a 30 cm strip to be placed over the first coat while still wet (Refer to the “Application Details” section).
- 4.5 After the first layer is tack-free, apply the second coat of **Aquathane E400** with brush or roller at a rate of 0.55 - 0.65 kg/m², perpendicular to the first coat, recoat time should be between 6 to 24 hours from the first coat.



Application of Aquathane E400

Notes:

- For spraying with an airless spray machine, **Aquathane E400** can be diluted by 15% with clean water (consult DCP's technical department for further details).
- If the substrate is susceptible to cracking, and for extra crack bridging ability, it is recommended to use **DonFlash H** as a reinforcement layer between the coats for the whole application area.
- Do not apply more than 0.65 kg/m² per coat if no reinforcement is used.
- **Aquathane E400** should not be subjected to permanent water immersion.
- Do not apply **Aquathane E400** on substrates that have rising damp

Consumption of Aquathane E400

- First coat: 0.55 - 0.65 kg/m².
- Second coat: 0.55 - 0.65 kg/m².
- Total consumption: 1.1 - 1.3 kg/m² to provide 500 microns dry film thickness.

5.0 Application Details

Parapet Flashing

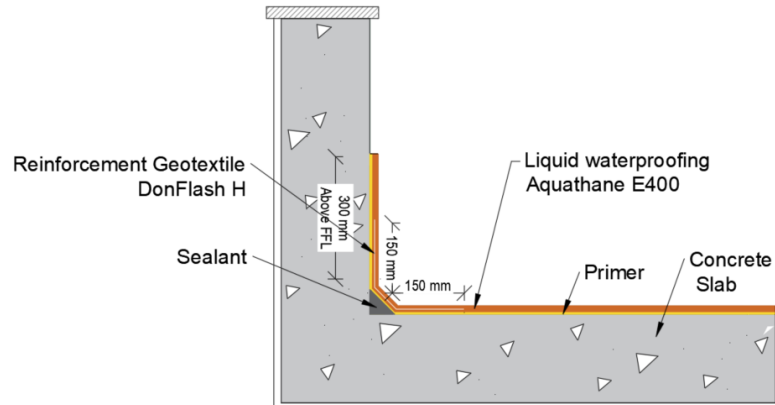

Rain Water Outlet

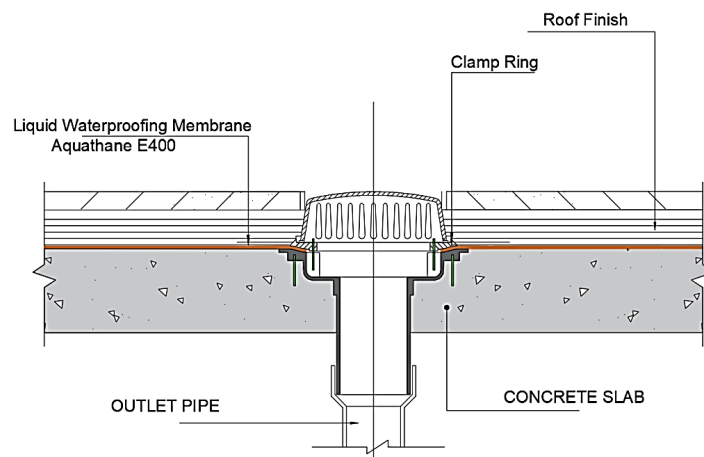

Pipe Through Slab

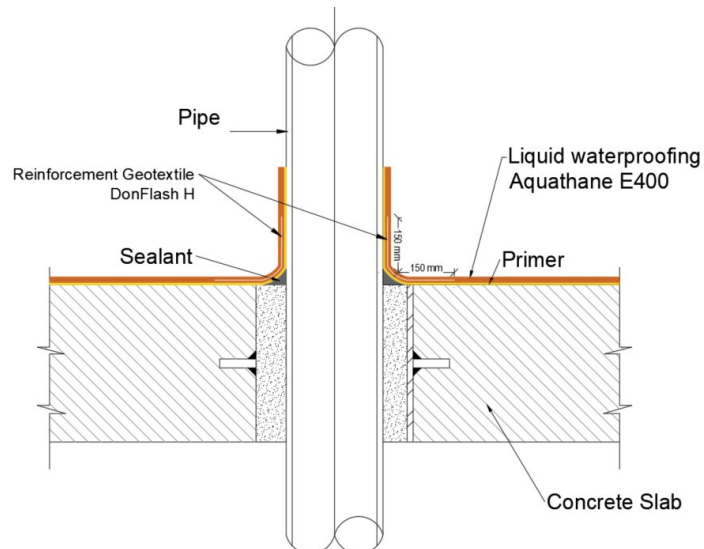



6.0 Cleaning and Storage

- 6.1 Tools and equipment can be cleaned from fresh material with a paper towel and wiped using water.
- 6.2 **Aquathane E400** has a shelf life of 12 months from the date of manufacture if stored in the original unopened pails at temperatures between 5°C and 25°C.
- 6.3 If these conditions are exceeded, DCP Technical Department should be contacted for advice.

Section C : Cautions

Health and safety

Aquathane E400 should not come into contact with skin and eyes. In case of contact with eyes immediately flush with plenty of water and seek medical advice promptly. Apply in well-ventilated areas. In closed areas use force ventilated and carbon active masks.

Fire:

Aquathane E400, Flexseal PU425/PU440 are nonflammable.

For further information on refer to the Material Safety Data Sheet.

Section D : Approval and Variations

This method statement is offered by DCP as a 'standard proposal' for the application of **Aquathane E400**. It remains the responsibility of the Engineer to determine the correct method for any given application. Where alternative methods are to be used, these must be submitted to DCP for approval, in writing, prior to commencement of any work. DCP will not accept responsibility or liability for variations to the above method statement under any other condition.